

# Common Applications for the Scanwill MP Hydraulic Pressure Intensifiers



More Pressure. More Power



1. Workholding
2. Mining
3. Production Lines
4. Pressure Testing
5. Tube Forming
6. Cylinder Test
7. Pressure Die Casting
8. Hydraulic Tools
9. Filter Presses
10. Mobile
11. Tensioning
12. Hydroforming
13. Increasing the pressure in a single acting cylinder
14. Increasing the pressure in a double acting cylinder - with bypass

The Scanwill Pressure Intensifiers allow to keep the energy consumption low, contributing to reach goal no. 12 in the world sustainability target.

12 RESPONSIBLE CONSUMPTION AND PRODUCTION



More information on [www.scanwill.com](http://www.scanwill.com)

# The Scanwill MP Hydraulic Pressure Intensifiers in Work Holding applications



More Pressure. More Power



The MP-T intensifier (In-Line)

The MP- intensifier (cetop / NG6)



The Scanwill MP- intensifiers are used to increase the pressure from a machine tool HPU, typically 50 - 100 bar to end pressures in the range 150 - 500 bar

Clamping

Un-Clamping

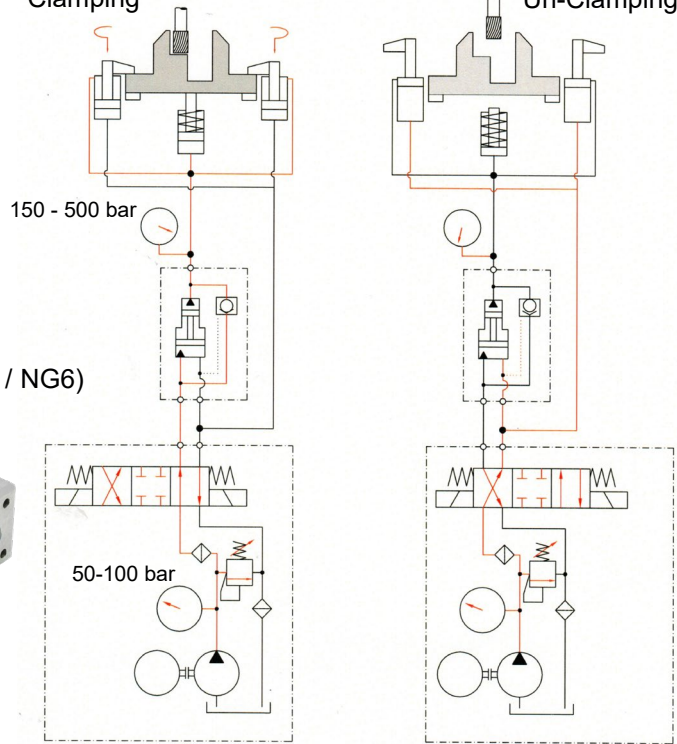

The MP-F intensifier (Flange-On)



The Scanwill Pressure Intensifiers allow to keep the energy consumption low, contributing to reach goal no. 12 in the world sustainability target.



More information on [www.scanwill.com](http://www.scanwill.com)

# The Scanwill MP Hydraulic Pressure Intensifiers in Mining applications



More Pressure. More Power



The Scanwill MP- intensifiers are used to increase the pressure from 100 - 200 bar to end pressures in the range 350 - 800 bar for brake systems and for support cylinders.

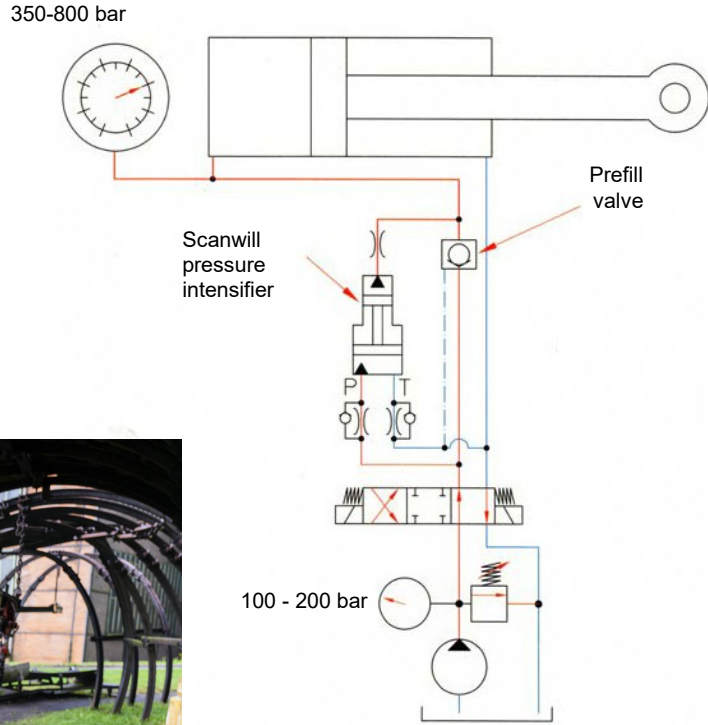

The MP- intensifier (cetop / NG6) for braking circuits

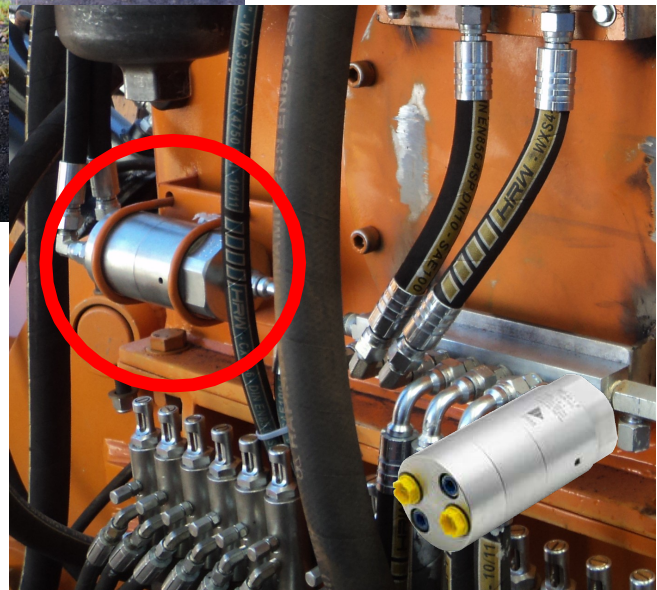

The MP-M intensifier (in-line) for support cylinders

More information on [www.scanwill.com](http://www.scanwill.com)

The Scanwill Pressure Intensifiers allow to keep the energy consumption low, contributing to reach goal no. 12 in the world sustainability target.



# The Scanwill MP Hydraulic Pressure Intensifiers increasing the pressure in Production Lines



More Pressure. More Power



In large systems there can be problems maintaining the pressure for all functions, or a higher pressure is required for one function. The Scanwill intensifiers can be inserted where needed ensuring sufficient pressure for all functions.

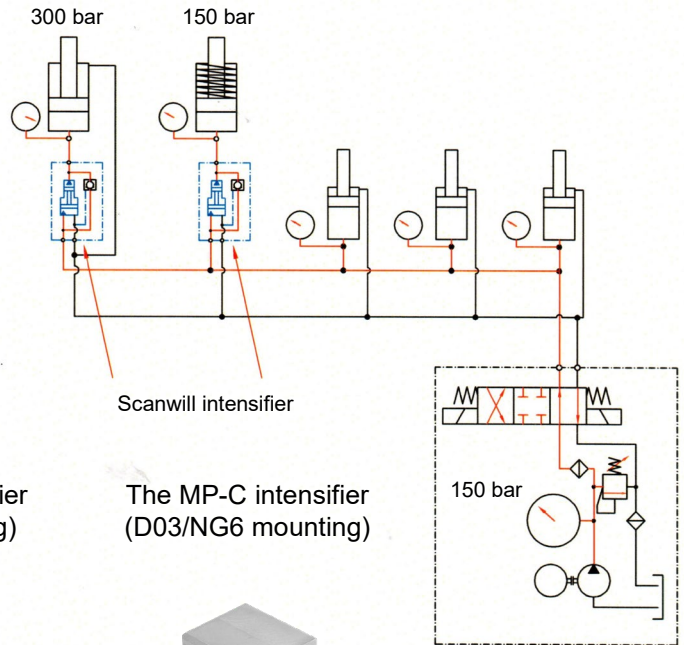

The MP-T intensifier (In-Line)

The MP-F intensifier (Flange mounting)

The MP-C intensifier (D03/NG6 mounting)



More information on [www.scanwill.com](http://www.scanwill.com)

The Scanwill Pressure Intensifiers allow to keep the energy consumption low, contributing to reach goal no. 12 in the world sustainability target.



# The Scanwill MP Hydraulic Pressure Intensifiers for Pressure Testing



The Scanwill MP- intensifiers are used to provide test pressures for hydraulic components (500 - 800 bar) and for tubes and hoses for diesel engines (2,000+ bar)

More Pressure. More Power



Pressurizing

De-pressurizing

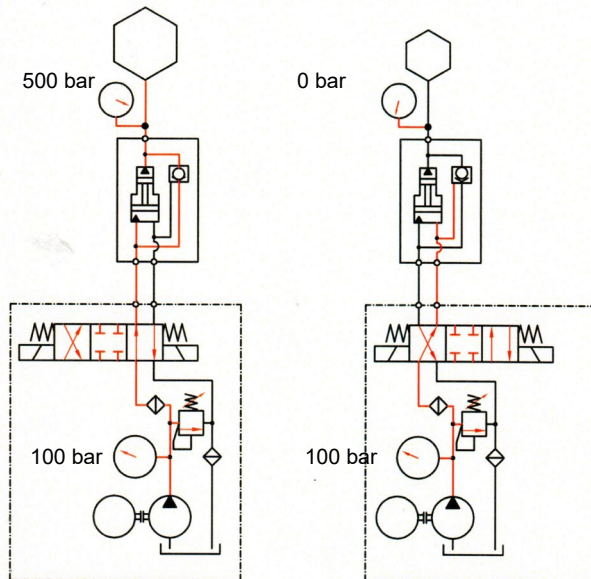

The MP-T intensifier (In-Line)

Test pressures up to 800 bar

The MP-L intensifier (In-Line, high flow)

Test pressures up to 800 bar

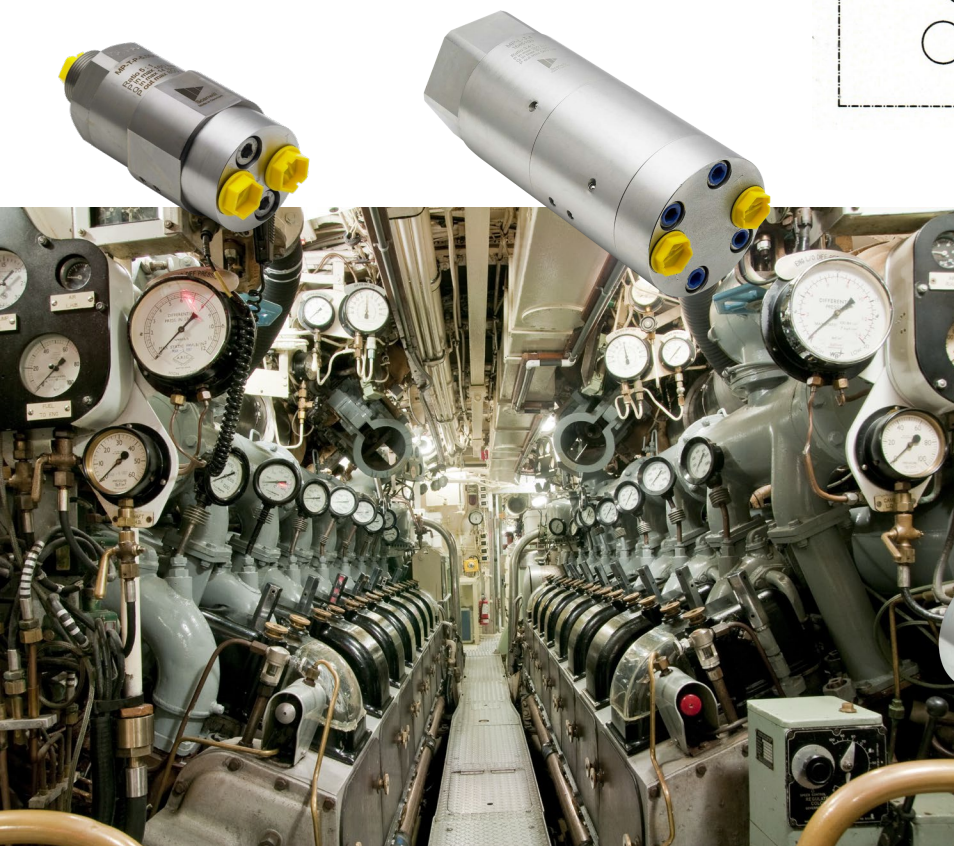

The MP-2000 intensifier (In-Line)

Test pressures up to 2,500 bar



The MP-4000 intensifier (In-Line)

Test pressures up to 4,000 bar



More information on [www.scanwill.com](http://www.scanwill.com)

The Scanwill Pressure Intensifiers allow to keep the energy consumption low, contributing to reach goal no. 12 in the world sustainability target.

12 RESPONSIBLE CONSUMPTION AND PRODUCTION



# The Scanwill MP Hydraulic Pressure Intensifiers used for Tube forming



More Pressure. More Power



MP-L intensifier used to increase the pressure for forming an exhaust pipe at a car manufacturing plant.



The Scanwill MP- intensifiers are used to increase the pressure from 140-200 bar to end pressures in the range 500 - 800 bar for forming the tube end.

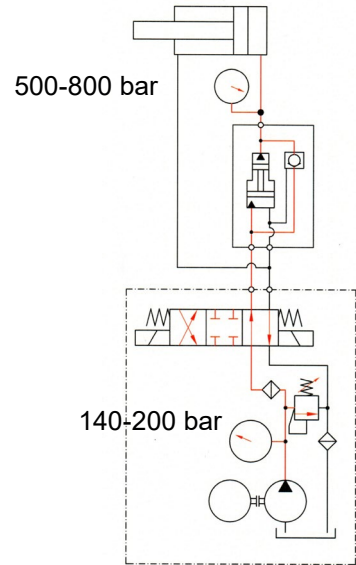

The MP-T intensifier (in-line)

The MP-M intensifier (in-line)



The MP-L intensifier (in-line)

More information on [www.scanwill.com](http://www.scanwill.com)

The Scanwill Pressure Intensifiers allow to keep the energy consumption low, contributing to reach goal no. 12 in the world sustainability target.



# The Scanwill MP Hydraulic Pressure Intensifiers in Cylinder Test applications



More Pressure. More Power



The Scanwill MP- intensifiers are used to increase the pressure from an HPU, typically 175 bar to end pressures in the range 350 - 500 bar

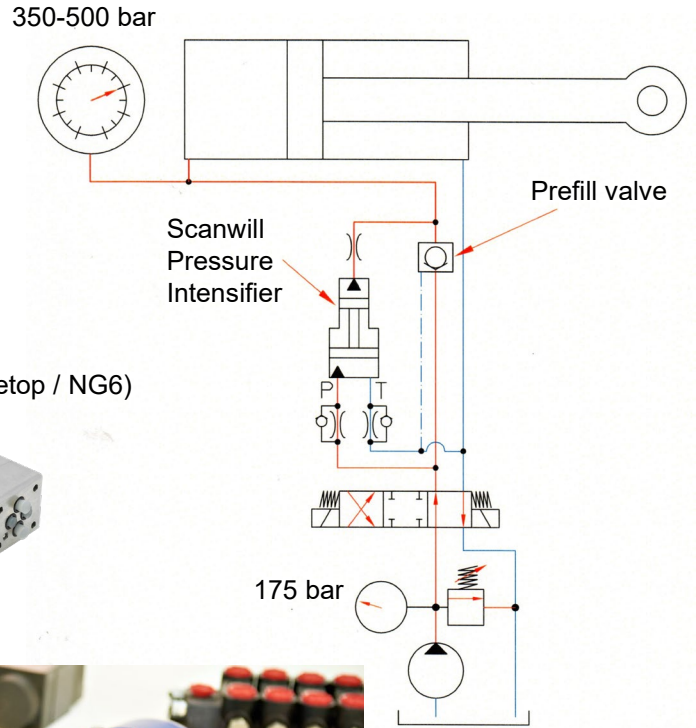

The MP-T intensifier (in-line)



The MP- intensifier (cetop / NG6)



The MP-M intensifier (in-line)

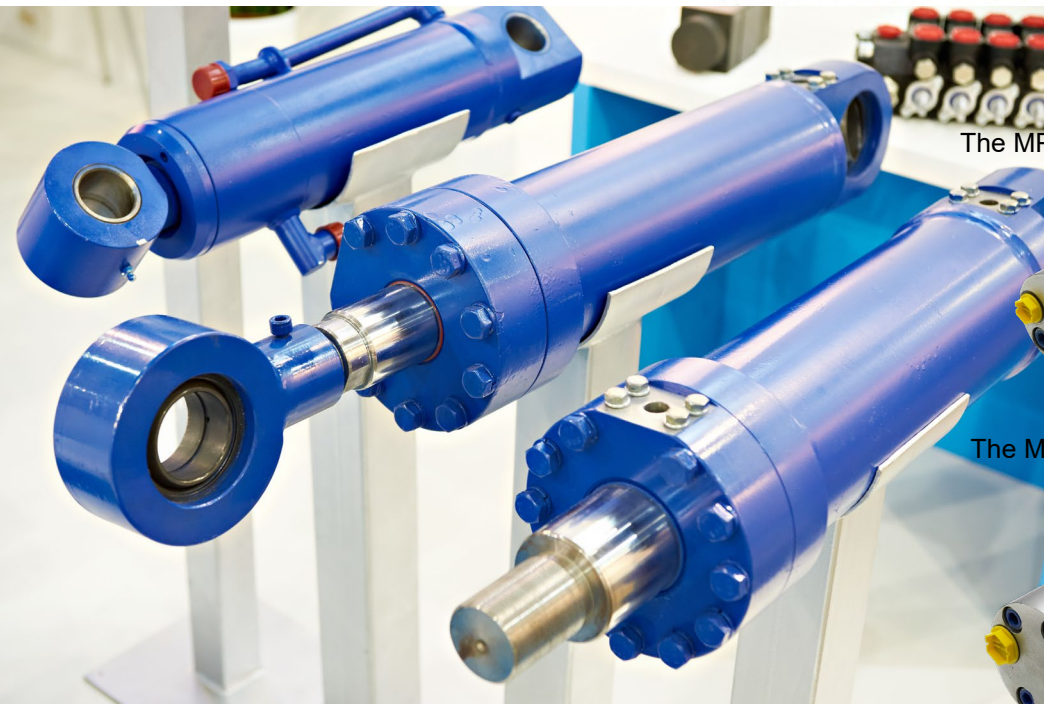

The MP-L intensifier (in-line)



More information on [www.scanwill.com](http://www.scanwill.com)

The Scanwill Pressure Intensifiers allow to keep the energy consumption low, contributing to reach goal no. 12 in the world sustainability target.



# The Scanwill MP Hydraulic Pressure Intensifiers in Pressure Die Casting applications



More Pressure. More Power



The Scanwill intensifiers are used to give extra power to core pulling cylinders, and to increase the pressure for squeezing the material to avoid air pockets in the material.

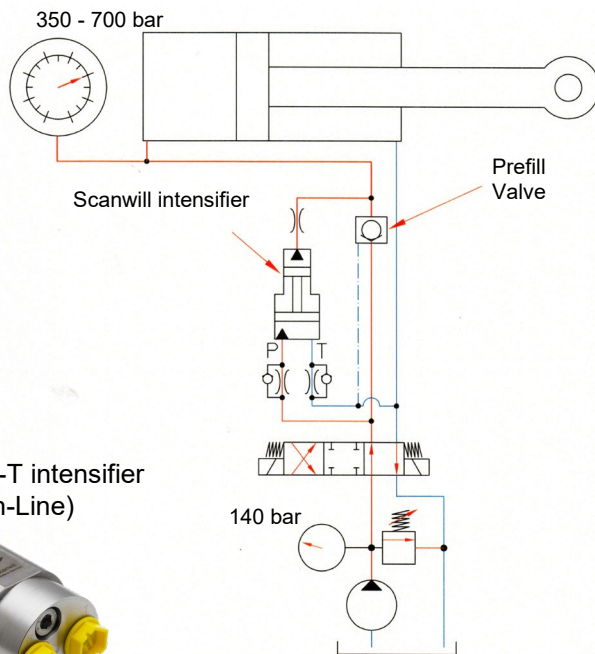

Scanwill intensifier on a mould

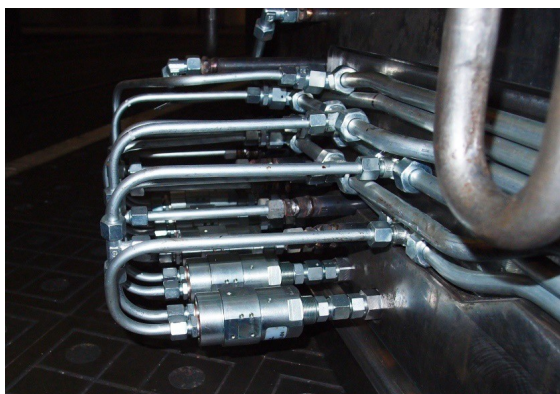

The MP-T intensifier (In-Line)



The MP-M intensifier (In-Line)



The MP-L intensifier (In-Line)

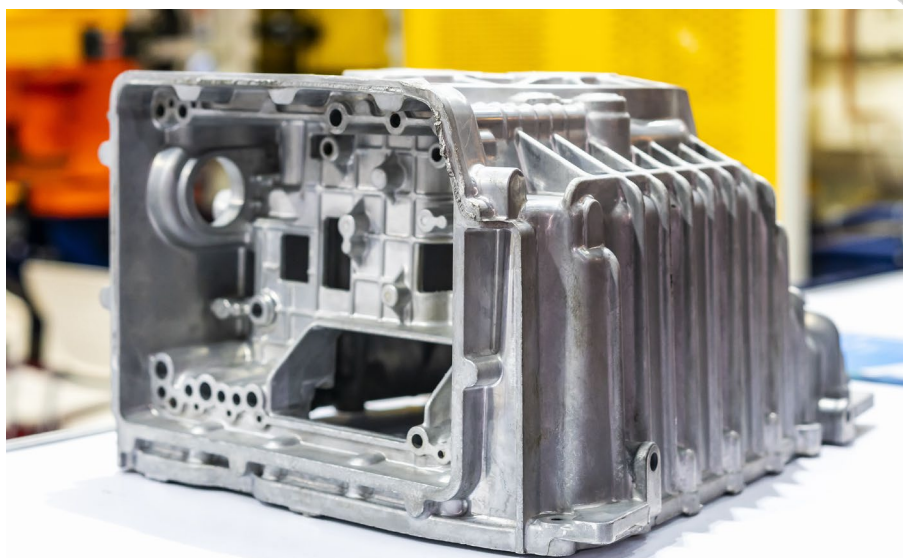

More information on [www.scanwill.com](http://www.scanwill.com)

The Scanwill Pressure Intensifiers allow to keep the energy consumption low, contributing to reach goal no. 12 in the world sustainability target.

12 RESPONSIBLE CONSUMPTION AND PRODUCTION





# The Scanwill MP Hydraulic Pressure Intensifiers for Hydraulic Tools



The Scanwill MP- intensifiers are used to boost a pump pressure 100-200 bar to operational pressures of 300 - 800 bar. With a Scanwill intensifier the tools can be operated from existing hydraulic power sources.

More Pressure. More Power



The MP-T intensifier (In-Line)

Exit pressures up to 800 bar



The MP-F intensifier (Flange mounting)

exit pressures up to 700 bar

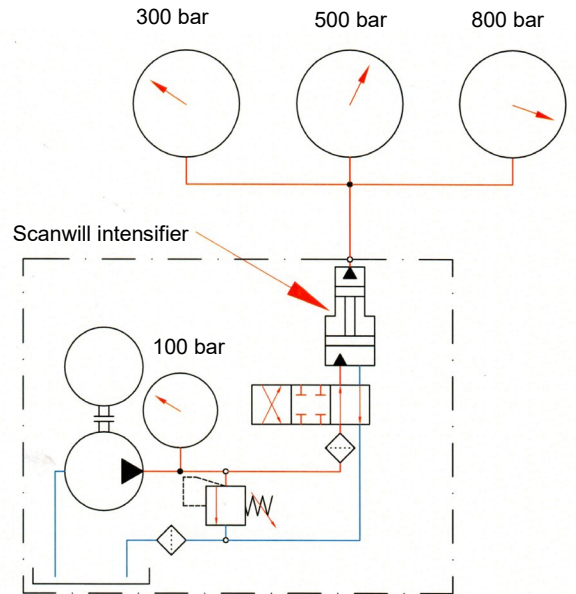

More information on [www.scanwill.com](http://www.scanwill.com)

The Scanwill Pressure Intensifiers allow to keep the energy consumption low, contributing to reach goal no. 12 in the world sustainability target.



# The Scanwill MP Hydraulic Pressure Intensifiers in Filter Presses



More Pressure. More Power



Scanwill intensifier on a HPU



The Scanwill intensifiers are used to give increase the pressure for clamping the filter elements, enabling the use of a smaller HPU and to use smaller cylinders.

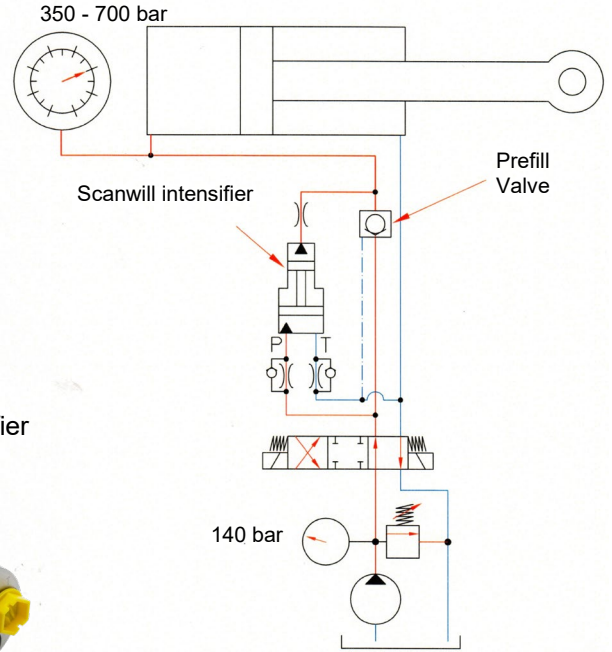

The MP-T intensifier (In-Line)



The MP-L intensifier (In-Line)

More information on [www.scanwill.com](http://www.scanwill.com)

The Scanwill Pressure Intensifiers allow to keep the energy consumption low, contributing to reach goal no. 12 in the world sustainability target.



# The Scanwill MP Hydraulic Pressure Intensifiers in Mobile Applications



The Scanwill MP- intensifiers are used to increase the pressure in the crane cylinders, when they move out, and to ensure sufficient pressure in the stabilizers. The end pressures in this application are between 250 and 350 bar.

More Pressure. More Power



250 - 350 bar

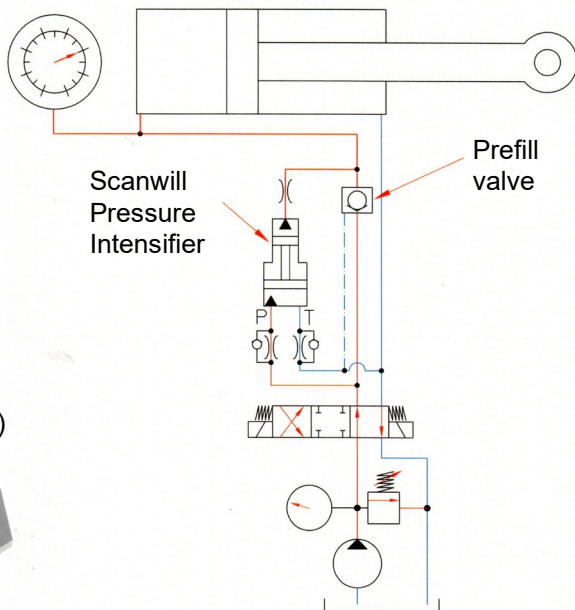

The MP-M intensifier (in-line)

The MP-L intensifier (in-line)



More information on [www.scanwill.com](http://www.scanwill.com)

The Scanwill Pressure Intensifiers allow to keep the energy consumption low, contributing to reach goal no. 12 in the world sustainability target.

12 RESPONSIBLE CONSUMPTION AND PRODUCTION



# The Scanwill MP-2000 Hydraulic Pressure Intensifiers in Tensioning Applications



The Scanwill MP-2000 intensifiers are mounted on standard HPU's supplying 1,000 - 3,000 psi, and will boost the pressure to 10,000 - 46,000 psi enabling the operation of hydraulic tensioners and tools.

More Pressure. More Power



The MP-2000 intensifier



Bolt tensioning tool

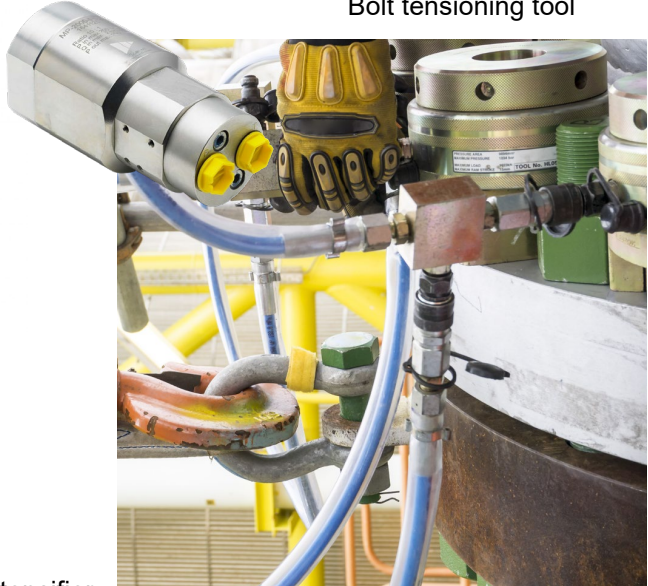

The XP-2000 intensifier

Tower and wing assembly for wind turbines



More information on [www.scanwill.com](http://www.scanwill.com)

The Scanwill Pressure Intensifiers allow to keep the energy consumption low, contributing to reach goal no. 12 in the world sustainability target.



# The Scanwill MP Hydraulic Pressure Intensifiers used for Hydroforming



More Pressure. More Power



The workpiece to be formed is filled with fluid, and the intensifier subsequently increase the internal pressure to 800 - 3,000 bar forming the workpiece to its final shape.

The MPL-4000 intensifier (in-line)



The MP-L intensifier (in-line)

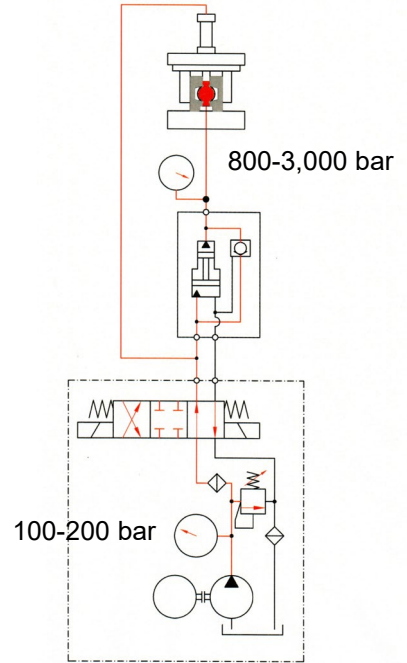

The MP-2000 intensifier (in-line)

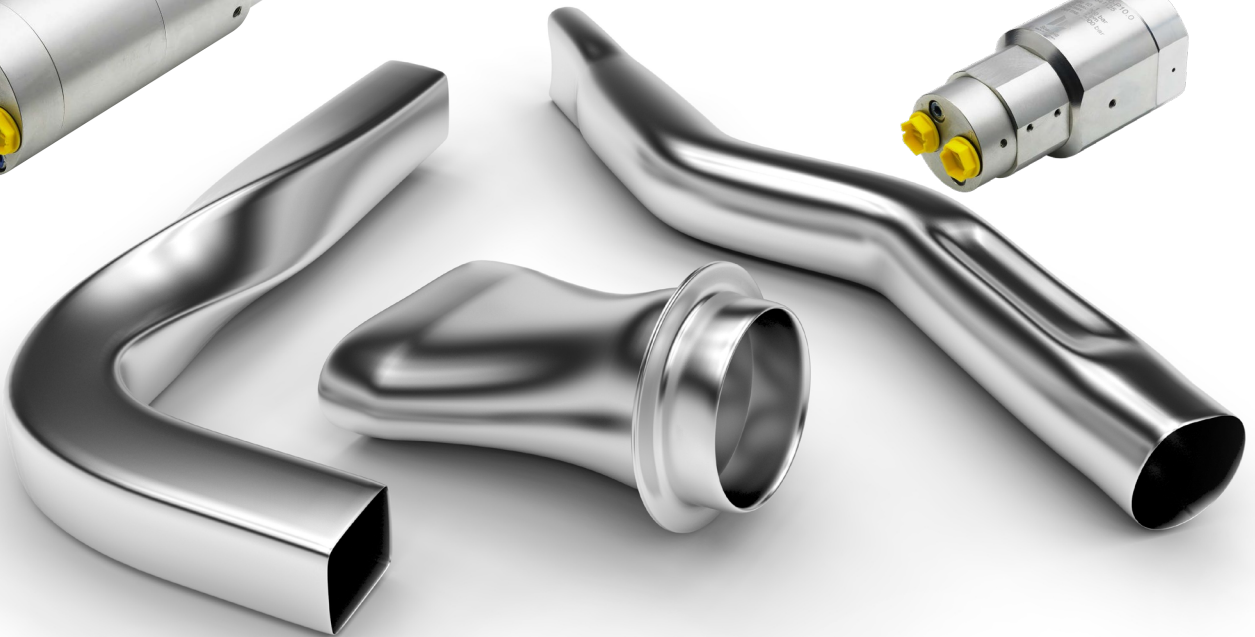

More information on [www.scanwill.com](http://www.scanwill.com)

The Scanwill Pressure Intensifiers allow to keep the energy consumption low, contributing to reach goal no. 12 in the world sustainability target.





ScanWill®  
More Pressure. More Power

## Increasing the pressure in a single acting cylinder

The pump flow goes through the check valves CV1 and CV2 integrated in the intensifier, and the cylinder rod moves fast forward.

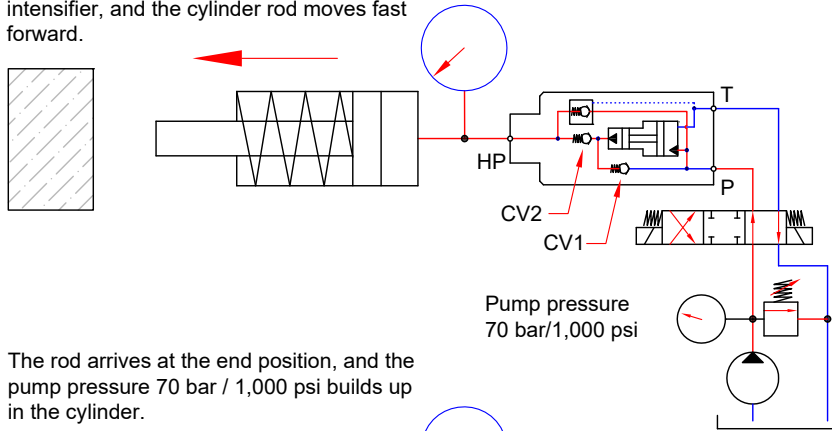

The rod arrives at the end position, and the pump pressure 70 bar / 1,000 psi builds up in the cylinder.

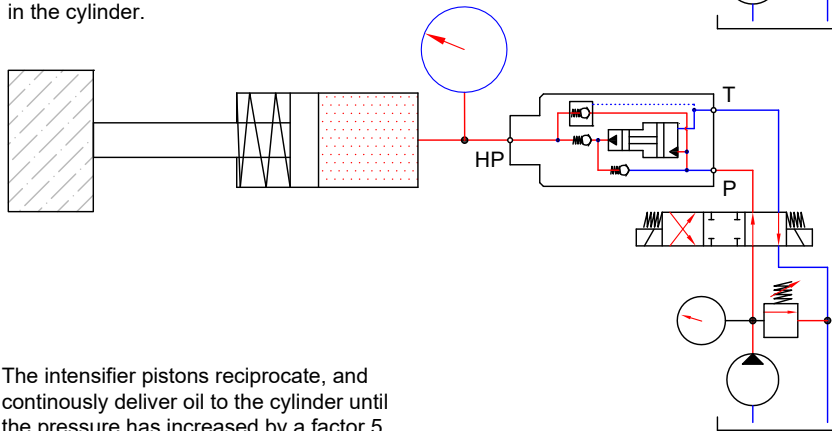

The intensifier pistons reciprocate, and continuously deliver oil to the cylinder until the pressure has increased by a factor 5 to 350 bar / 5,000 psi

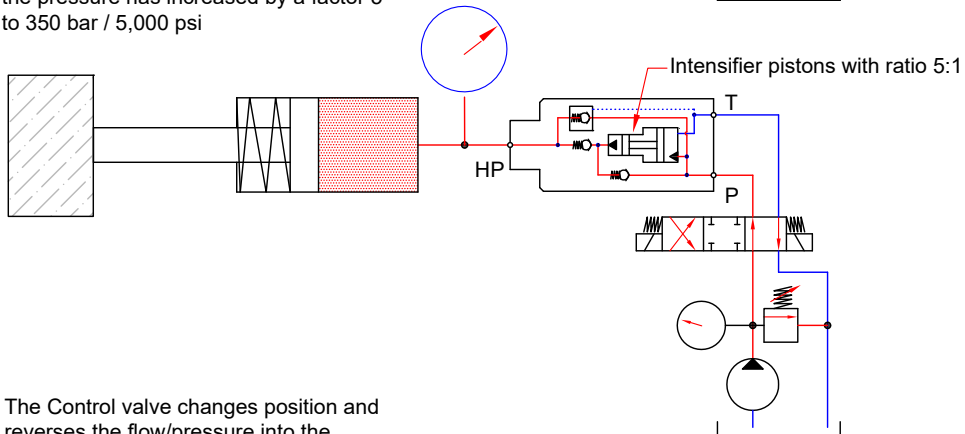

The Control valve changes position and reverses the flow/pressure into the intensifier ports P and T. This opens the POV, providing a direct path back to tank, and the cylinder rod retracts.

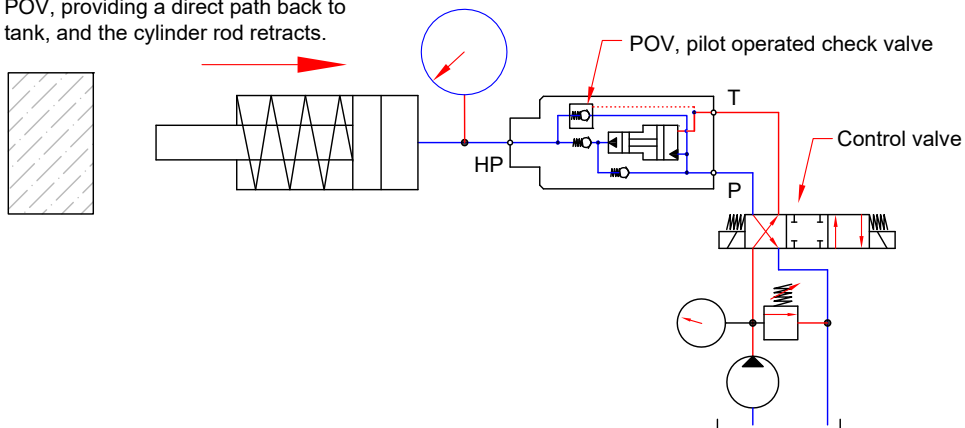

## Increasing the pressure in a double acting cylinder - with bypass

The pump flow goes through the external pilot operated check valve 1

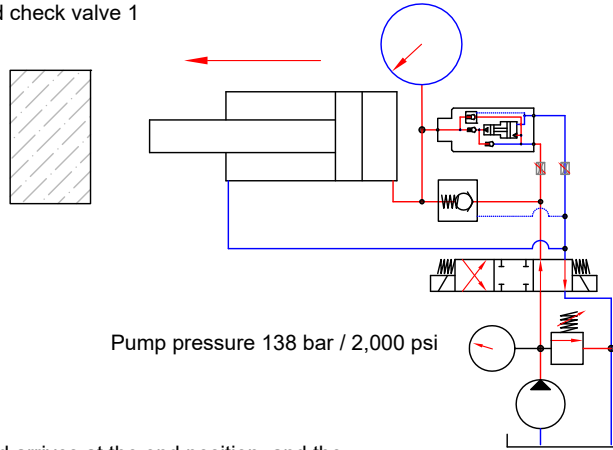

The rod arrives at the end position, and the pressure in the cylinder raises to pump pressure 138 bar / 2,000 psi

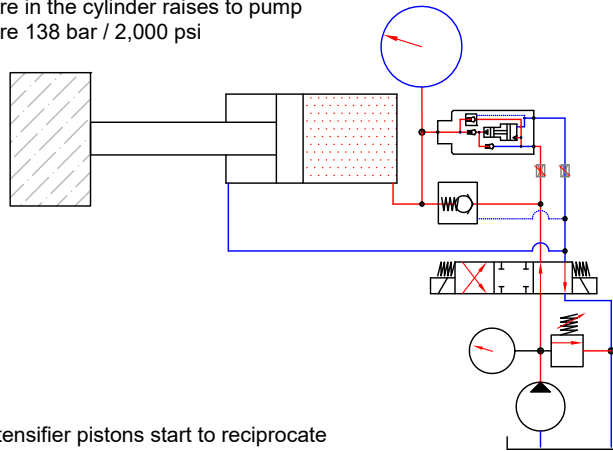

The intensifier pistons start to reciprocate increasing the pressure by a factor 3, and the pressure in the cylinder to 414 bar / 6,000 psi

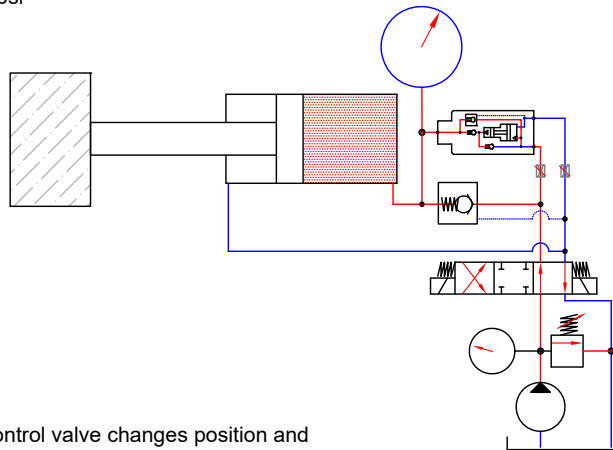

The control valve changes position and the external pilot operated check valve opens, and the cylinder returns.

