

## Operation Instructions for the MP-2100 Pressure Intensifier

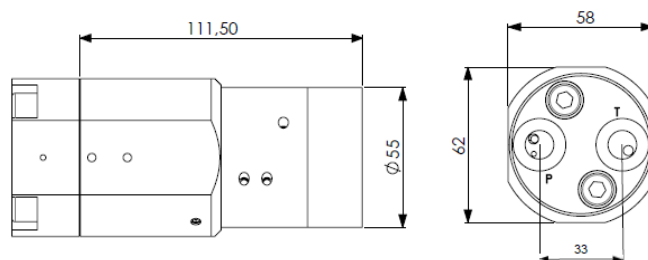
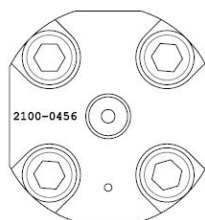
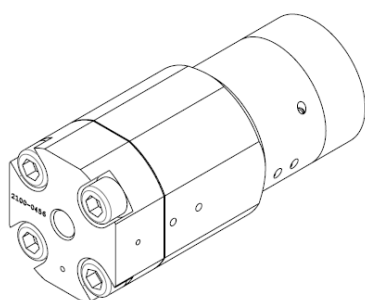

### Port sizes

P and T: G1/4" (1/4" BSPP) or 7/16"-20 UNF  
HP: See below

### Before installing the intensifier

Ensure the surroundings and the connecting parts are clean and free from burrs.

### Fluids

For use with standard hydraulic oils and water glycol (min. 5% glycol). Preferred viscosity range 20 - 46 cSt

### Filtration requirements

10 µm nominal or better, maximum 19/16 according to ISO 4406

### Connecting the intensifier

Connecting the MP-2100 pressure intensifier to a system is only to be done by trained personnel.

1. Connect the P-port of the intensifier to the hydraulic pressure supply.
2. Connect the T-port to the tank line.
3. Connect the HP-port to the end pressure line / cylinder.

### Hydraulic bleeding

During start-up of the system, it is recommended to ensure no air is trapped in the system, as this may cause function problems.

### HP-Port sizes

The HP port (outlet pressure) has several options, all of them sealing at a cone at the end of the bore. Most common are:

9/16"-18 UNF with 60° cone sealing and  
G1/4" (1/4" BSPP) with 120° cone sealing

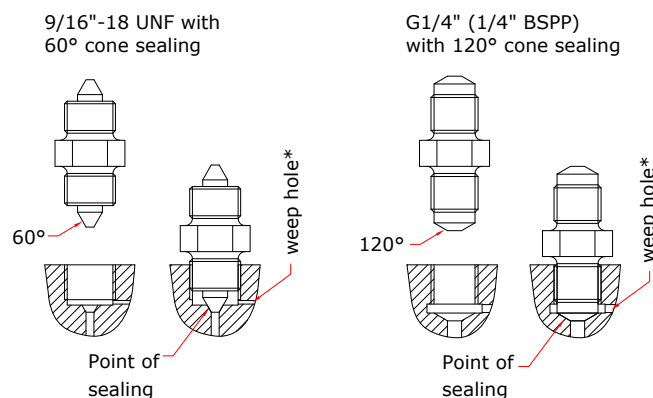

\*The weep hole is a safety measure to ensure the full high pressure is not acting on the thread. If oil/fluid is coming out of the weep hole, this is a sign that the fitting is loose, and needs to be tightened.

### ⚠ CAUTION:

Ensure the fittings and components on the output side are rated for the end pressure delivered by the Scanwill intensifier.

## Function

The MP-2100 is an in-line hydraulic pressure intensifier designed to increase a supplied pump pressure to a higher end pressure (for fluids only). The intensification ratio is fixed, and the end pressure is always proportional with the supplied pressure. Fig. 1 shows the schematic of the MP-2100 intensifier increasing the pressure in a single or double acting cylinder.

When applying flow to the P-port and connecting the T-port to tank, the full pump flow will go straight through the intensifier check valves CV1, CV2 and POV (optional) to the cylinder, allowing the rod to move out at pump speed. When the cylinder is filled up and the pressure has risen to pump pressure, the intensifier pistons automatically increase the pressure to the set end pressure. Keeping the pump connected ensures the intensifier will automatically work to maintain the end pressure in the cylinder, in case the pressure drops.

If the POV is integrated the cylinder can be retracted by connecting the P-port to tank and the T-port to pump. This will open the POV creating a free passage from the HP-side back to tank.

## High Flow Applications

In systems with flow rates larger than permissible for the intensifier, the inlet to the P and T ports must be limited according to the flow-pressure table below. To maintain the speed in the cylinder, an external p.o. check valve capable of handling the system flow and end pressure can be inserted in parallel with the MP-2100 hydraulic pressure intensifier

Fig.1

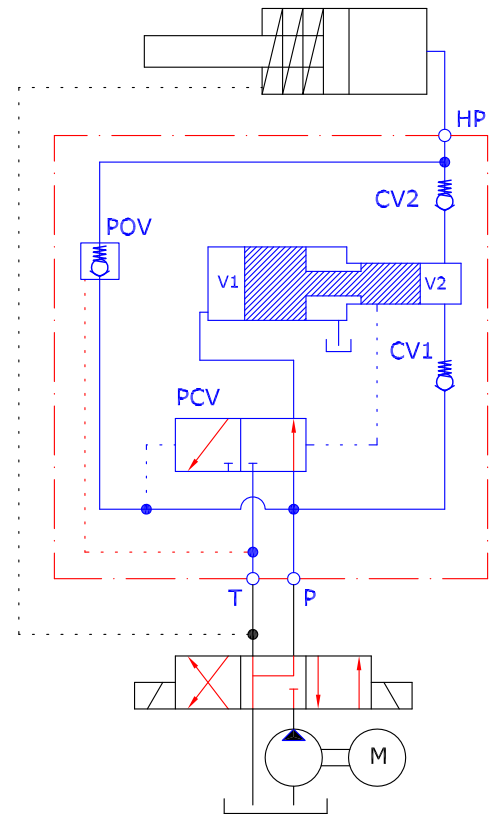

## Intensification ratios, flow and pressure settings

Product number*	Intensification ratio	Max. supply Flow** (LPM)	Outlet supply pressure*** (bar)	Average outlet Flow**** (LPM)	Outlet pressure range***** (bar)
MP-2100-S/P-7.0	7.0	15.0	200	0.3	140 - 1,400
MP-2100-S/P-10.0	10.0	15.0	200	0.3	200 - 2,000
MP-2100-S/P-13.0	13.0	14.0	200	0.2	260 - 2,600
MP-2100-S/P-16.0	16.0	12.0	200	0.2	320 - 3,200

\* S means intensification only, P means the p.o. check valve POV is integrated.

\*\* Max. supply flow limits not to be exceeded, as this will damage the internal check valves and over speed the intensifier pistons.  
Min. supply flow is 2 LPM

\*\*\* Max. supply pressure limits not to be exceeded, as this will cause damage to the intensifier parts, and will cause to high outlet pressure.  
Pressure spikes must be avoided.

\*\*\*\* The Average flow is the flow generated by the intensifier pistons when increasing the pressure from pump pressure to end pressure. Initially the flow is high, and as the pressure increases the flow decreases and will eventually stop when the end pressure has been reached.

\*\*\*\*\* The outlet pressure is proportional with the supplied pressure, and can be set at any value within the range.  
The max. pressure within the range for each intensification ratio must not be exceeded